

SRA-500XL Smoke Purifier

Instruction Booklet

I. Introduction to purification system

SRA-500XL Smoke Purifier is applicable to:

- Purification for laser marking, cutting, carving, welding,
- Smoke purification for wave soldering, reflow soldering;
- Smoke purification for tin furnace and multi station soldering;
- Other smoke and dust purification.

With a high-pressure and high-speed centrifugal blower, SRA-500XL smoke purifier enjoys the characteristics of great suction, low energy consumption and long service life, which ensures the effective absorption of smoke particles and extends the service life of the filter core to the maximum.

By PWM speed regulation, the control system can continuously and precisely adjust the air volume according to the amount of smoke generated.

Scientific filtration gradient setting: primary and secondary filtration plus HEPA efficient filtration with purified particles of 0.3 μm in diameter, a purification rate of 99.99%, and a lasting service life of filter core.

Gas filtration layer: columnar activated carbon particles plus molecular sieve and oxidant, etc. With the characteristics of large specific surface area, super strong suction power and a thickness up to 70mm, it enjoys a more complete and thorough filtration as well as a lasting service life.

II. Structure schematic drawing

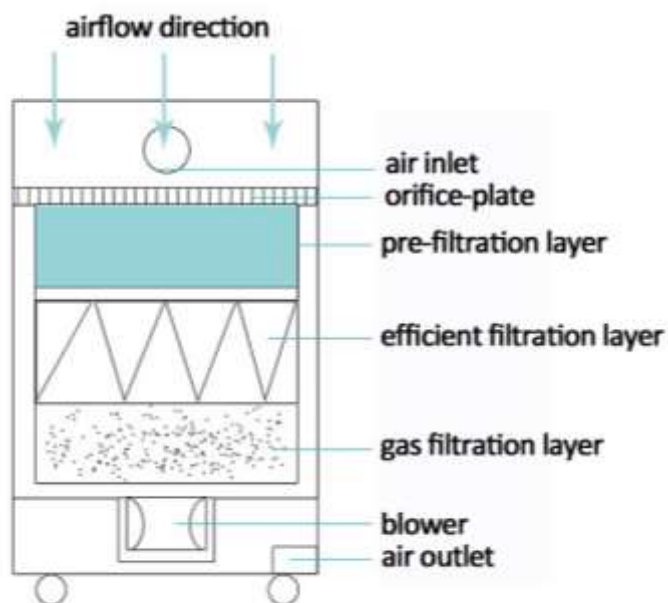

III. The main technical parameters

Model	SRA-500XL
Dimension	450×490×880mm
Power Supply	220V, 50Hz
Power	320w
Air volume	480 m ³ /h (Adjustable air inflow)
Wind pressure	3200Pa
Air inlet	φ75mm×2
Noise level	52dBA
Control system	PWM velocity modulation, acousto-optic warning
Weight	53Kg

IV. Structure schematic drawing



V. Installation and operation instructions

1. Power source's connection

Before connecting the power source, must confirm whether the use voltage frequency does match with the equipment rated voltage frequency.

2. Hose's connection

The hose and equipment's connection needs to seal suitably, and the hose do not press folds the influence air current to pass.

3. Operating equipment

- 1) Press down the power switch, the switch green indicating lamp lightens; the indicating lamp twinkle moment, treats when continues to lighten, the machine starts the movement.

2) Adjust the wind speed knob.

Turn the knob clockwise to increase the air volume; turn it anticlockwise to decrease the air volume. When the air volume is increased or decreased, there is a slight delay.

3) The digital tube displays the percentage of pressure difference in real time.



Note: the air volume switch needs to be adjusted to the maximum.

4) Indicator light & Digital display

3-level light indication: normal, warning and replacement. The green light indicates normal. When $50\% < \text{filter core block rate} \leq 80\%$, the yellow warning light is on, while, when filter core block rate exceeds 80%, the red light flashes, accompanied with a buzzing sound, prompting to replace the filter core in time.



5) After all pipes are installed, the initial value may not be "0" due to the influence of pipeline wind resistance, etc., at this time, the equipment needs to be reset. The specific operation is as follows:

	
Adjust the air volume to the maximum and open the fan access door	Find the "A1" button on the circuit board, press and hold for 5 seconds, and release it after hearing the "tick" sound.

★ Recommended replacement cycle of consumables:

Pre-filter: 1-3 months.

Main filter and gas filter: 6-12 months (for reference only, subject to actual working conditions)

VI. Filter element replacement explanation

After the filter element uses period of time, regardless of needs to replace or the migration, must wear the protective glove and the mask. After machine control warning, prompts us to replace the filter element promptly.

1. Replaces the pre-filter wears the glove and the protection mask.

Loosen the buckle of the cover and open the machine. Take out the pre-filter, packed into the plastic bag and sealed .Replace the new pre-filter, then turn off the cabinet door.

2. Replaces the main filter wears the glove and the protection mask.

Loosen the buckle of the cover and open the machine. Take out the main-filter, packed into the plastic bag and sealed .Replace the new main-filter, then turn off the cabinet door. The machine will run in normal.

VII. Matters need attention

1. 220V and 50Hz power supply is suitable for this machine and requires good grounding.
2. Please check the overall sealing before using the equipment, for example, whether the sealing strip at the bottom of the filter is intact, whether it is placed flat, whether the tube connection is sealed, etc.

Note: It is strictly forbidden to remove the filter element before use!

3. Please cut off the power supply if not used for a long time.
4. Do not install the machine in direct sunlight, otherwise, the cabinet may cause deformation or the machine may not work properly.
5. The working environment of the machine should not exceed 80 ℃, and the machine should not be operated in a very humid environment with a high concentration of combustible gas.
6. When the filter is used for a period of time, please wear protective gloves and masks regardless of the need to replace or move.
7. The machine should be used on a solid and flat ground to avoid the noise caused by the shaking of the machine, and the fixed casters of the equipment should be stepped on to prevent the equipment from sliding.
8. If there is any abnormality, please cut off the power and notify the seller to appoint a professional to carry out maintenance.
9. Before starting the machine, open the cabinet door and check whether the filter element is moved or misplaced. If the above condition occurs, please reorganize the filter element.